

# FIRE SUPPRESSION



**Response Fire Systems Ltd.  
2710 Beachmount Crescent  
Kamloops, BC V2B 0E6**

**Date: June 1, 2022**

### **Warranty**

**Re: Altitude**

**This letter verifies a warranty period of one year for parts and labor for the specified location and dates.**

**Location: Altitude – Sun Peaks**

**From:** The date of occupancy

**To:** One year past occupancy

**Warranty coverage:** All labor, piping, fittings, sprinklers & equipment attached to the new wet sprinkler and standpipe system. The water service pipe that connects the sprinkler system to the city mains was installed by others and is not covered under this warranty.

**Sincerely, Morgan Martel - Principal**



**Response Fire Systems Ltd.**  
**2710 Beachmount Crescent**  
**Kamloops, BC V2B 0E6**  
**morgan@responsefire.ca**

**Date:** June 1, 2022

**Re:** Altitude

The entire building is protected by an automatic sprinkler system that is charged with water at all times. The water flow is controlled by individual sprinkler heads. These sprinkler heads are heat actuated and require a temperature of 155°F to discharge. Water will continue to flow after the sprinkler has discharged until the appropriate main control valve is shut off. Each unit has an individual shut off valve (zone valve) and drain valve. The locations of these valves are in the mechanical rooms of each unit.

It is very important that the owners are familiar with the locations of the main control valves in case of an emergency due to a non-fire condition. A sprinkler system main control valve should never be closed until the fire department determines that a fire condition does not exist. Once a sprinkler head has discharged it must be replaced and pressure restored to the system. This work can only be performed by a qualified sprinkler fitter with the appropriate insurance.

Attached to this is a complete list of material specifications and maintenance requirements of all the equipment installed on the fire sprinkler system.

For any questions, service, inspections or maintenance requirements please call Morgan Martel at Response Fire Systems Ltd. At 250-578-7779, cell 250-319-5604 or email [morgan@responsefire.ca](mailto:morgan@responsefire.ca)



**Job or Customer:** .....  
**Engineer:** .....  
**Contractor:** .....  
**Submitted by:** ..... **Date** .....  
**Approved by:** ..... **Date** .....  
**Order No:** ..... **Date** .....  
**Specification:** .....  
**Installation Date:** .....

### < STANDARDS >

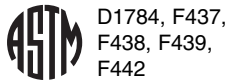

## introduction

IPEX BlazeMaster® pipe and fittings are designed specifically for fire sprinkler systems. They are made from a specialty thermoplastic known chemically as post-chlorinated polyvinyl chloride (CPVC). IPEX BlazeMaster pipe and fittings provide unique advantages in sprinkler installations including superior hydraulics, ease of joining, increased hanger spacing in comparison to other thermoplastics and ease of assembly. They also are based on a technology with a continuous and proven service history of more than 40 years.

### Fire Performance

BlazeMaster is made with CPVC which offers an even greater fire safety profile than PVC. Like PVC, CPVC will not independently support combustion, and as such will not burn once the flame source is removed. CPVC's ignition resistance is demonstrated by its flash ignition temperature of 900°F.

CPVC also has a low flame spread. In addition, it provides outstanding smoke characteristics. In testing conducted to CAN/ULC S102.2, CPVC showed a flame spread of less than 15, and a smoke-developed classification of 15. And, like PVC, CPVC has a fuel contribution of 0.





### material properties

Physical & Thermal Properties of BlazeMaster CPVC		
Property	CPVC	ASTM
Specific Gravity	1.55	D792
IZOD Impact Strength (ft. lbs./inch, notched)	3.0	D256A
Modulus of Elasticity, @ 73°F, psi	4.23 x 10 <sup>5</sup>	D638
Ultimate Tensile Strength, psi	8,400	D638
Compressive Strength, psi	9,600	D695
Poisson's Ratio	.35 - .38	-
Working Stress @ 73°F, psi	2,000	D1598
Hazen-Williams C Factor	150	-
Coefficient of Linear Expansion in./in.°F)	3.4 x 10 <sup>-5</sup>	D696
Thermal Conductivity BTU/hr.ft. <sup>2</sup> /°F/in.	0.95	C177
Limiting Oxygen Index	60%	D2863
Electrical Conductivity	Non Conductor	

### availability

Description	Size (in)
<b>Pipe</b>	3/4" to 3"
<b>Fittings</b>	
Tee (Soc)	3/4" to 3"
Reducing Tee (Soc)	3/4" to 3" x 3/4" 3" x 3/4" to 2-1/2"
Sprinkler Head Adapter Tee (Soc x Soc x SST FPT)	3/4" to 2" x 3/4" 2" x 1/2"
Sprinkler Head Adapter Tee (FPT x FPT x Soc)	1/2" x 1/2" 1"
90° Elbow (Soc)	3/4" - 3"
Sprinkler head Adapter 90° Elbow (Soc x SST FPT)	3/4" to 1-1/4" x 1/2" to 3/4"
45° Elbow (Soc)	3/4" to 3"
Cross (Soc)	3/4" to 2-1/2"
Coupling (Soc)	3/4" to 3"
Grooved Adapter Coupling (Soc x Groove)	1-1/4" to 3"
Female Adaptor (Soc x SST FPT)	3/4" to 2"
Sprinkler Head Adaptor (Soc x SST FPT)	3/4" to 1-1/4" x 1/2" to 3/4"
Sprinkler Head Adaptor (Sp x SST FPT)	3/4" to 1" x 1/2"
Reducer Bushing (Spig x Soc)	1" to 3" x 3/4" to 2-1/2"
Cap (Soc)	3/4" to 3"
Union (Soc)	3/4" to 2"
One Piece Flange (Soc)	3/4" to 3"



### Outdoor Installations

IPEX BlazeMaster pipe and fittings are not listed for exposed, outdoor applications.

### Joining IPEX BlazeMaster Pipe and Fittings with Red One Step Solvent Cement

Note: BlazeMaster BM-5 One Step Cement requires no cleaner or primer. Refer to individual manufacturers' installation instructions.

### Cutting

IPEX BlazeMaster pipe can be easily cut with a sharp ratchet cutter (except at temperatures below 10°C (50°F)), a wheel-type plastic tubing cutter, a power saw or a fine toothed saw. To ensure the pipe is cut square, a miter box is recommended when using a saw. A square cut provides the surface of the pipe with maximum bonding area. If any indication of damage or cracking is evident at the pipe end, cut off at least 50.8 mm (2") beyond any visible crack.



### Deburring

Burrs and filings can prevent proper contact between pipe and fitting during assembly, and must be removed from the outside and the inside of the pipe. A chamfering tool or a file is suitable for this purpose. A slight bevel shall be placed at the end of the pipe to ease entry of the pipe into the socket and minimize the chances of wiping solvent cement from the fitting during insertion.



### Fitting Preparation

Using a clean, dry rag, wipe loose dirt and moisture from the fitting socket and pipe end. Moisture can slow the cure time and at this stage of assembly, excessive water can reduce joint strength. Check the dry fit of the pipe and fitting. The pipe should enter the fitting socket easily 1/4 to 3/4 of the way. At this stage, the pipe should not bottom out in the socket.

### Solvent Cement Application

Joining surfaces shall be penetrated and softened. Cement shall be applied (worked into pipe) with an applicator half the nominal size of the pipe diameter. Apply a heavy, even coat of cement to the outside pipe end. Apply a medium coat to the fitting socket.

Pipe sizes 1-1/4" (32 mm) and above shall always receive a second cement application on the pipe end. (Apply cement on the pipe end, in the fitting socket, and on the pipe again.) Only use solvent cements that have been specifically investigated and tested for use with BlazeMaster CPVC systems and approved by the pipe and fitting manufacturer. Too much cement can cause clogged waterways. Do not allow excess cement to puddle in the pipe and fitting assembly.



Special care shall be exercised when assembling BlazeMaster systems in extremely low temperatures (below 4°C (40°F)) or extremely high temperatures (above 38°C (100°F)). Extra set time shall be allowed in colder temperatures. When cementing pipe and fittings in extremely cold temperatures, make certain that the cement has not "gelled". Gelled cement must be discarded. In extremely hot temperatures, make sure both surfaces to be joined are still wet with cement when putting them together.



### Assembly

After applying cement, immediately insert the pipe into the fitting socket, while rotating the pipe one-quarter turn. Properly align the fitting for the installation at this time. Pipe must bottom to the stop. Hold the assembly for 10 to 15 seconds to ensure initial bonding. A bead of cement should be evident around the pipe and fitting juncture. If this bead is not continuous around the socket shoulder, it may indicate that insufficient cement was applied.



If insufficient cement is applied, the fitting must be cut out and discarded.

Cement in excess of the bead can be wiped off with a rag. Care shall be exercised when installing sprinkler heads. Sprinkler head fittings shall be allowed to cure for a minimum of 30 minutes prior to installing the sprinkler head. When installing sprinkler heads, be sure to anchor or hold the pipe drop securely to avoid rotating the pipe in previously cemented connections. Previously cemented fittings shall also be permitted to cure for a minimum of 30 minutes.

**Warning:** Sprinkler heads shall be installed only after all the CPVC pipe and fittings, including the sprinkler head adapters, are solvent welded to the piping and allowed to cure for a minimum of 30 minutes. Sprinkler head fittings should be visually inspected and probed with a wooden dowel to ensure that the water way and threads are clear of any excess cement. Once the installation is complete and cured per Table I, II or III, the system shall be hydrostatically tested. Sprinklers shall not be installed in the fittings prior to the fittings being cemented in place.

**Note:** Safety and Health Precautions. Prior to using CPVC solvent cements, review and follow all precautions found on the container labels, material safety data sheet, and Standard Practice for Safe Handling ASTM F 402.

### Set and Cure Times

Solvent cement set and cure times are a function of pipe size, temperature, relative humidity, and tightness of fit. Curing time is faster for drier environments, smaller pipe sizes, higher temperatures and tighter fits. The assembly must be allowed to set, without any stress on the joint, for 1 to 5 minutes, depending on pipe size and temperature.



Following initial set period, the assembly can be handled carefully, avoiding significant stresses to the joint. Refer to the following tables for minimum cure times prior to pressure testing.

Pipe Size		Temperature		
inches	mm	16°C to 49°C (60°F to 120°F)	≥ 4.4°C (≥ 40°F)	≥ 17.8°C (≥ 0°F)
3/4	20	1 hr	4 hrs	48 hrs
1	25	1-1/2 hrs	4 hrs	48 hrs
1-1/4	32 & 40	3 hrs	32 hrs	10 days
2	50	8 hrs	48 hrs	Note 1
2-1/2 & 3	65 & 80	24 hrs	96 hrs	Note 1

Note: Cure times indicated in Table 1 are to be used for all LPCB approved pipe and fitting joints.

Pipe Size		Temperature		
inches	mm	16°C to 49°C (60°F to 120°F)	≥ 4.4°C (≥ 40°F)	≥ 17.8°C (≥ 0°F)
3/4	20	45 mins	1-1/2 hrs	48 hrs
1	25	45 mins	1-1/2 hrs	48 hrs
1-1/4	32 & 40	1-1/2 hrs	16 hrs	10 days
2	50	6 hrs	36 hrs	Note 1
2-1/2 & 3	65 & 80	8 hrs	72 hrs	Note 1

Pipe Size		Temperature		
inches	mm	16°C to 49°C (60°F to 120°F)	≥ 4.4°C (≥ 40°F)	≥ 17.8°C (≥ 0°F)
3/4	20	15 mins	15 mins	30 mins
1	25	15 mins	30 mins	30 mins
1-1/4	32 & 40	15 mins	30 mins	2 hrs

Note: For these sizes, the solvent cement can be applied at temperatures below -17.8°C (0°F), however, the sprinkler system temperature must be raised to a temperature of 0°C (32°F) or above and allowed to cure per the above recommendations prior to pressure testing.



### Threaded Connections

IPEX BlazeMaster CPVC female threaded adapters or flanges are listed for connecting a BlazeMaster fire sprinkler system to other materials, valves, and appurtenances.

A thread sealant shall be used in making threaded connections. TFE (Teflon®) thread tape is the recommended sealant. Some thread sealants other than TFE thread tape contain solvents or other materials that may be damaging to CPVC. Contact your authorized IPEX BlazeMaster distributor or IPEX Representative for approved thread sealants. Use of thread sealants other than those approved by IPEX will void the warranty on the IPEX BlazeMaster system.

Care shall be exercised when transitioning between IPEX BlazeMaster pipe and fittings and metal. Care must be taken to avoid over-torquing. Refer to section on instructions for torque requirements.

The following is the recommended method of installation to ensure a sound connection.

- a) Begin by applying 2 to 3 wraps of TFE (Teflon®) thread tape.
- b) Tighten the sprinkler head into the adapter taking care not to cross-thread the fitting. (Recommended torque values 15-25 ft/lbs)
- c) Two to three turns beyond finger-tight is all that is required to make a sound plastic threaded connection.

**CAUTION:** Over-tightening will damage both the pipe and the fitting.

### Flanged Connections

Flange Make-Up: Once a flange is joined to pipe, the method for joining two flanges is as follows:

1. Piping runs joined to the flanges must be installed in a straight line position to the flange to avoid stress at the flange due to misalignment. Piping must also be secured and supported to prevent lateral movement that can create stress and damage the flange.
2. With gasket in place, align the bolt holes of the mating flanges by rotating the ring into position. (Consideration should be given to alignment of One-Piece Flange prior to joining with pipe.)
3. Insert all bolts, washers (two standard flat washers per bolt), and nuts.
4. Make sure the faces of the mating surfaces are flush against gasket prior to bolting down the flanges.
5. Tighten the nuts by hand until they are snug. Establish uniform pressure over the flange face by tightening the bolts in 5 ft. lb. (6.8 M Kg) increments according to the sequence shown in Figure 8: Bol Tightening Sequence following a 180° opposing sequence.
6. Care must be taken to avoid “bending” the flange when joining a flange to a “raised face” flange, or a wafer-style valve. Do not use bolts to bring together improperly mated flanges.

**Caution:** Over-torquing will damage the flange. Torque given is for dry, non-lubricated bolt, standard washers, neoprene 3.18 mm (1/8<sup>2</sup>) thick full face gasket. If lubricant (non-petroleum based) is used, torque levels may vary. Actual field conditions may require a variation in these recommendations.

**Figure 8:  
Bolt Tightening  
Sequence**

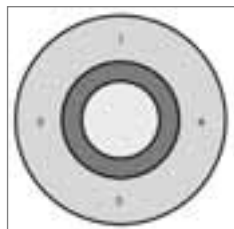

Recommended Bolt Torque					
Flange Size		Bolt Diameter		Torque	
inches	mm	inches	mm	ft lbs	M Kg
3/4 - 1-1/2	19.05 - 38.10	1/2	12.70	10 - 15	13.6 - 20.3
2 - 3	50.80 - 76.20	5/8	15.88	20 - 30	27.1 - 40.7

### Grooved Coupling Adapters

The following procedures are recommended for proper assembly of the Grooved Coupling Adapter. READ THESE INSTRUCTIONS CAREFULLY BEFORE BEGINNING INSTALLATION.

1. Inspect the fittings and pipe to insure that they are sufficiently free from indentations, projections or roll-marks on the gasket seating areas of the fitting and pipe. The pipe should be squarely cut with any loose scale, paint and/or dirt must be removed from the groove and seating surface. Use a standard grade E\*, EPDM compound that is suitable for wet fire sprinkler service. A flexible coupling shall be used with grooved coupling adapters. Caution: Use of rigid style couplings may damage the grooved coupling adapter. Consult the coupling manufacturer for proper selection.

\*See manufacturer for temperature ratings.

2. Make sure the gasket is clean and free of any cracks, cuts or other defects which may cause leaks. Lubricate the gasket with a vegetable soap-based gasket lubricant. Caution: Use of petroleum based lubricants will damage the gasket and adapter resulting in stress failure of the CPVC adapter. A gasket/joint lubricant is recommended to prevent pinching the gasket and to assist in seating the gasket during the alignment process. Apply the appropriate lubricant to the gasket lips and exterior surface of the gasket.
3. Place the gasket over the metal pipe ends, being sure gasket lip does not overhang the pipe end. Insert the CPVC grooved coupling adapter into the gasket. Make sure that the gasket is centered between the two grooves. No portion of the gasket should extend into the grooves. Caution: Make sure the gasket is not pinched between the pipe and the fitting.
4. Place the metal housing over the gasket, making sure the metal housing key is into the grooves on the metal pipe and the CPVC coupling adapter. Insert the bolts and tighten by hand. Tighten the bolts alternately and equally until the bolt pads are touching metal-to-metal. In completing a proper joint, the gasket is also slightly compressed, adding to the strength of the seal from the gasket's durometer.
5. Inspect the joints before and after pressure testing. Look for gaps between the bolt pads and for housing keys that are not inside the grooves.

### Penetrating Fire Rated Walls and Partitions

Before penetrating fire rated walls and partitions, consult building codes and authorities having jurisdiction in your area. Several classified through-penetration firestop systems are approved for use with CPVC pipe. Consult IPEX representative for further information. Warning: Some firestop sealants or wrap strips contain solvents or plasticizers that may be damaging to CPVC. Always consult the manufacturer of the firestop material for compatibility with IPEX BlazeMaster CPVC pipe and fittings.

### Earthquake Bracing

Since IPEX BlazeMaster CPVC pipe is more ductile than metallic sprinkler pipe, it has a greater capacity to withstand earthquake damage. In areas subject to earthquakes, BlazeMaster fire sprinkler systems shall be designed and braced in accordance with local codes or NFPA 13, Section 6-4 (1999 Edition).

When it is required to earthquake brace BlazeMaster piping, it is important to use fittings, fasteners or clamps that do not have sharp edges or apply excessive compressive forces sufficient to distort the pipe.

### Pressure Testing

Once an installation is completed and cured, per the previous recommendations, the system should be hydrostatically (water) pressure tested at 1379 kPa (200 psi), Table II, for 2 hours (or at 345 kPa (50 psi) in excess of the maximum pressure, Table I, when the maximum pressure to be maintained in the system is in excess of 1034 kPa (150 psi) in accordance with the requirements established by NFPA Standard 13, Section 10-2.2.1 (1999 Edition). Sprinkler systems in one- and two-family dwellings and mobile homes may be tested at line pressure, Table III in accordance with the requirements established by NFPA 13D, Section 1-5.4 (1999 Edition). When pressure testing, the sprinkler system shall be slowly filled with water and the air bled from the highest and farthest sprinkler heads before pressure testing is applied. Air must be removed from piping systems (plastic or metal) to prevent it from being locked in the system when pressure is applied. Entrapped air can generate excessive surge pressures that are potentially damaging, regardless of the piping materials used. **Air or compressed gas should never be used for pressure testing.** If a leak is found, the fitting must be cut out and discarded. A new section can be installed using couplings or a union. Unions should be used in accessible areas only.



### Scope

This specification sheet covers IPEX Inc. requirements for for 3/4" through 3" (20 mm – 75 mm) **BlazeMaster CPVC SDR 13.5 Pipe** for wet pipe automatic sprinkler systems, having a rated working pressure of 175 psi (1205 kPa) at 150°F (66°C) or 315 psi (2172 kPa) at 73°F (22°C) and **BlazeMaster CPVC Schedule 80 Fittings**. The fittings, for wet pipe automatic sprinkler systems, having a rated working pressure of 175 psi (1205 kPa) at 150°F (66°C) or 315 psi (2172 kPa) @ 73°F (22°C). These products meet or exceed performance standards set by the American National Standards Institute (ANSI), the American Society for Testing and Materials (ASTM), Factory Mutual Research (FM), National Fire Protection Agency (NFPA), NSF International (NSF), Underwriters Laboratories Inc., and Underwriters' Laboratories of Canada (ULC).

Underwriters' Laboratories of Canada lists **BlazeMaster CPVC Schedule 80 Fittings** and **BlazeMaster CPVC SDR 13.5 Pipe** for use in the following applications; Residential occupancies as defined in the Standard for Sprinkler Systems in One and Two-Family Dwellings, NFPA 13D.

Multiple residential as defined in NFPA 13R.

Light-hazard occupancies as defined in the Standard for Installation of Sprinkler Systems, NFPA 13. **BlazeMaster CPVC Schedule 80 Fittings** and **BlazeMaster CPVC SDR 13.5 Pipe** can be used for both concealed and exposed installations. Refer to IPEX literature for any limitations.

### Dimensions

IPEX BlazeMaster pipe is produced in SDR 13.5 dimensions to the specifications of ASTM F442. Fittings are produced to ASTM F437, F438 pr F439 specifications depending on the size and configuration.

### Material

**BlazeMaster CPVC SDR 13.5 Pipe** are made from Lubrizol Inc. Chlorinated Polyvinyl Chloride (CPVC) raw material having a cell class of 23447 as defined in ASTM Standard D 1784 "Standard Specification for Rigid Polyvinyl Chloride (PVC) and Chlorinated Polyvinyl Chloride (CPVC) Compounds". The compound is listed with NSF for potable water service.

The material has been tested in accordance with CAN/ULC Standard S102.2M88 "Standard Method of Test for Surface Burning Characteristics of Flooring, Floor Covering, and Miscellaneous Materials and Assemblies" with the following results: Flame Spread 5 / Smoke Development 5-15.

**BlazeMaster Schedule 80 Fittings** are made from Lubrizol Inc. Chlorinated Polyvinyl Chloride (CPVC) raw material having a cell class of 23447 as defined in ASTM Standard D 1784 "Standard Specification for Rigid Polyvinyl Chloride (PVC) and Chlorinated Polyvinyl Chloride (CPVC) Compounds". The compound is listed with NSF for potable water service.

### Marking

**BlazeMaster Schedule 80 Fittings** and **BlazeMaster CPVC SDR 13.5 Pipe** are made from Lubrizol Inc. Chlorinated Polyvinyl Chloride (CPVC) raw material having a cell class of 23447 as defined in ASTM Standard D 1784 "Standard Specification for Rigid Polyvinyl Chloride (PVC) and Chlorinated Polyvinyl Chloride (CPVC) Compounds". The compound is listed with NSF for potable water service.





### About the IPEX Group of Companies

As leading suppliers of thermoplastic piping systems, the IPEX Group of Companies provides our customers with some of the world's largest and most comprehensive product lines. All IPEX products are backed by more than 50 years of experience. With state-of-the-art manufacturing facilities and distribution centers across North America, we have established a reputation for product innovation, quality, end-user focus and performance.

Markets served by IPEX group products are:

- Electrical systems
- Telecommunications and utility piping systems
- PVC, CPVC, PP, ABS, PEX, FR-PVDF and PE pipe and fittings (1/4" to 48")
- Industrial process piping systems
- Municipal pressure and gravity piping systems
- Plumbing and mechanical piping systems
- PE Electrofusion systems for gas and water
- Industrial, plumbing and electrical cements
- Irrigation systems

Products are manufactured by IPEX Inc. and distributed in the United States by IPEX USA LLC. PlumbBetter® is a trademark of IPEX Branding Inc.

This literature is published in good faith and is believed to be reliable. However, it does not represent and/or warrant in any manner the information and suggestions contained in this brochure. Data presented is the result of laboratory tests and field experience.

A policy of ongoing product improvement is maintained. This may result in modifications of features and/or specifications without notice.





**“THE INCH”  
RESIDENTIAL  
AUTOMATIC SPRINKLERS  
MODEL GL4906  
ONE INCH ADJUSTABLE  
FLAT PLATE CONCEALED PENDENT**

**DESCRIPTION AND OPERATION**

The Globe Model GL4906 Residential One Inch Adjustable Concealed Pendent Sprinkler has a flat plate profile that utilizes a 3mm frangible glass ampule as the thermosensitive element. It features economy, aesthetics and the lowest allowable water flow with a nominal 1" of adjustment for easier installation. The combination of the 3mm frangible glass ampule and specially designed deflector make the Model GL4906 the ultimate in life safety and fire control. It has met the strict requirements of Underwriters Laboratories Inc. as described in UL Standard, 1626, for Residential Sprinklers for Fire Protection Service, and should be used accordingly. This sprinkler should also be installed in accordance with the appropriate NFPA Standard 13, 13D or 13R and under the direction of the approving authorities having jurisdiction.

All that is seen at the ceiling is the 3 5/16" diameter flat ceiling plate color finished to match the specifier's exact requirements. The ceiling plate is soldered to the sprinkler's special upper support assembly in three places. Upon the application of sufficient heat, the plate falls to the floor exposing the residential pendent spray sprinkler. At the prescribed temperature the internal pressure within the ampule exceeds the strength of the glass causing the glass bulb to shatter. This results in water discharge which is distributed in an approved pattern.

**TECHNICAL DATA**

- See reverse side for Approvals and Specifications.
- Temperature Rating - 155°F (68°C)
- Water Working Pressure Rating - 175 psi (12 Bars)
- Factory tested hydrostatically to 500 psi (34 Bars)
- Maximum low temperature glass bulb rating is -67°F (-55°C)
- Frame - bronze • Deflector - brass • Screw - brass
- Lodgement Wire - stainless steel • Bulb seat - copper
- Spring - nickel alloy • Seal - teflon
- Bulb - glass with alcohol based solution, 3mm size
- Cover Plate - brass • Upper Escutcheon Assembly - steel



**RESIDENTIAL  
FLAT PLATE CONCEALED  
PENDENT**

**• SPRINKLER TEMPERATURE RATING/CLASSIFICATION and COLOR CODING**

CLASSIFICATION	AVAILABLE SPRINKLER TEMPERATURES	BULB COLOR	N.F.P.A. MAXIMUM CEILING TEMPERATURE
ORDINARY	155°F      68°C	RED	100°F      38°C

**“THE INCH”  
RESIDENTIAL  
AUTOMATIC SPRINKLERS  
MODEL GL4906  
ONE INCH ADJUSTABLE  
FLAT PLATE CONCEALED PENDENT**

**SPECIFICATIONS AND APPROVALS**

SIN MODEL	NOMINAL “K” FACTOR	THREAD SIZE	LENGTH	FLAT COVER PLATE FINISHES	cULus CE
GL4906	4.9 (68 metric)	1/2”NPT (15mm)	3” (7.6cm)	Chrome White Painted Other Painted Finishes <sup>1,2</sup>	X

NOTE: METRIC CONVERSIONS ARE APPROXIMATE.

<sup>1</sup>FINISHES AVAILABLE ON SPECIAL ORDER.

<sup>2</sup>FOR PAINTED PLATES OTHER THAN WHITE, CONTACT GLOBE FOR ORDERING SPECIFICATIONS.

**INSTALLATION DATA FOR FLAT AND SLOPED CEILINGS\*\***

SIN MODEL	STYLE	SPRINKLER TEMPERATURE 155°F (68°C)	MAX. AREA OF COVERAGE <sup>3</sup> Feet (Meters)	*MIN. PRESSURE P.S.I. (bars)	*MIN. FLOW G.P.M. (L/min.)	MIN. DISTANCE BETWEEN SPRINKLERS Feet (Meters)
GL4906	"THE INCH" ONE INCH ADJUSTABLE CONCEALED PENDENT	X	12 (3.7) x 12 (3.7)	7.0 (.48)	13 (49)	9 (2.7)
		X	14 (4.3) x 14 (4.3)	7.0 (.48)	13 (49)	
		X	16 (4.9) x 16 (4.9)	7.0 (.48)	13 (49)	
		X	18 (5.5) x 18 (5.5)	12.0 (.83)	17 (64)	
		X	20 (6.1) x 20 (6.1)	16.7 (1.15)	20 (76)	

NOTE: METRIC CONVERSIONS ARE APPROXIMATE.

\*WHEN THESE SPRINKLERS ARE USED IN NFPA 13 SYSTEMS, A 0.1 DESIGN DENSITY MINIMUM SHALL BE UTILIZED.

\*\*REFER TO PAGE 2 OF GLOBE’S RESIDENTIAL SPRINKLER INSTALLATION GUIDE (BULLETIN R.S.I.G.) FOR NFPA 13D AND 13R REQUIREMENTS.

<sup>3</sup>FOR COVERAGE AREA DIMENSIONS LESS THAN OR BETWEEN THOSE INDICATED, USE THE MINIMUM REQUIRED FLOW FOR THE NEXT HIGHEST COVERAGE AREA FOR WHICH HYDRAULIC DESIGN CRITERIA ARE STATED.

**CROSS SECTION**

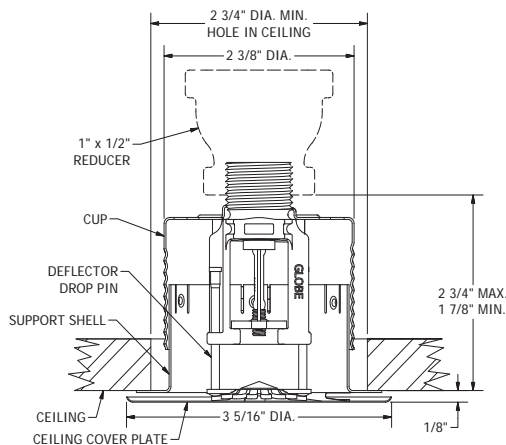

**1” ADJUSTMENT FLAT PLATE CONCEALED PENDENT**

FLAT COVER PLATE SIZE	WHITE 135°F (57°C) PART #	CHROME 135°F (57°C) PART #
3 5/16" DIA.	332892	332891

**ORDERING INFORMATION SPECIFY**

- Quantity • Model Number • Style
- Orifice • Temperature • Finishes desired
- Quantity - Wrenches - P/N 332765
- Quantity - Protective Caps - P/N 332868

**GLOBE® PRODUCT WARRANTY**

Globe agrees to repair or replace any of its own manufactured products found to be defective in material or workmanship for a period of one year from date of shipment.

For specific details of our warranty please refer to Price List Terms and Conditions of Sale (Our Price List).





Specifications subject to change without notice.

Ordering Information			
Nominal Pipe Size		Model	Part Number
2"	DN50	VSR-2 Canadian	1144502
2 1/2"	DN65	VSR-2 1/2 Canadian	1144525
3"	DN80	VSR-3 Canadian	1144503
3 1/2"	-	VSR-3 1/2 Canadian	1144535
4"	DN100	VSR-4 Canadian	1144504
5"	-	VSR-5 Canadian	1144505
6"	DN150	VSR-6 Canadian	1144506
8"	DN200	VSR-8 Canadian	1144508

**Optional:** Cover Tamper Switch Kit, stock no. 0090148

**Replaceable Components:** Retard/Switch Assembly, stock no. 1029030

**UL, CUL and CSFM Listed, FM Approved, LPCB Approved, For CE Marked (EN12259-5) / VdS Approved model use VSR-EU**

**Service Pressure:** 450 PSI (31 BAR) - UL

**Flow Sensitivity Range for Signal:**

4-10 GPM (15-38 LPM) - UL

**Maximum Surge:** 18 FPS (5.5 m/s)

**Contact Ratings:** Two sets of SPDT (Form C)

10.0 Amps at 125/250VAC

2.0 Amps at 30VDC Resistive

10 mAmps min. at 24VDC

**Conduit Entrances:** Two knockouts provided for 1/2" conduit.

Individual switch compartments suitable for dissimilar voltages.

**Environmental Specifications:**

- NEMA 4/IP54 Rated Enclosure suitable for indoor or outdoor use with factory installed gasket and die-cast housing when used with appropriate conduit fitting.
- Temperature Range: 40°F - 120°F, (4.5°C - 49°C) - UL
- Non-corrosive sleeve factory installed in saddle.

**Service Use:**

Automatic Sprinkler

NFPA-13

One or two family dwelling

NFPA-13D

Residential occupancy up to four stories

NFPA-13R

National Fire Alarm Code

NFPA-72

### ⚠ WARNING

- Installation must be performed by qualified personnel and in accordance with all national and local codes and ordinances.
- Shock hazard. Disconnect power source before servicing. Serious injury or death could result.
- Risk of explosion. Not for use in hazardous locations. Serious injury or death could result.

### CAUTION

Waterflow switches that are monitoring wet pipe sprinkler systems shall not be used as the sole initiating device to discharge AFFF, deluge, or chemical suppression systems. Waterflow switches used for this application may result in unintended discharges caused by surges, trapped air, or short retard times.

#### General Information

The Model VSR is a vane type waterflow switch for use on wet sprinkler systems. It is UL Listed and FM Approved for use on steel pipe; schedules 10 through 40, sizes 2" thru 8" (50 mm thru 200 mm). LPC approved sizes are 2" thru 8" (50 mm thru 200 mm). See Ordering Information chart.

The VSR may also be used as a sectional waterflow detector on large systems. The VSR contains two single pole, double throw, snap action switches and an adjustable, instantly recycling pneumatic retard. The switches are actuated when a flow of 10 GPM (38 LPM) or more occurs downstream of the device. The flow condition must exist for a period of time necessary to overcome the selected retard period.

#### Enclosure

The VSR switches and retard device are enclosed in a general purpose, die-cast housing. The cover is held in place with two tamper resistant screws which require a special key for removal. A field installable cover tamper switch is available as an option which may be used to indicate unauthorized removal of the cover. See bulletin number 5401103 for installation instructions of this switch.

**Installation** (see Fig. 1)

These devices may be mounted on horizontal or vertical pipe. On horizontal pipe they shall be installed on the top side of the pipe where they will be accessible. The device should not be installed within 6" (15 cm) of a fitting which changes the direction of the waterflow or within 24" (60 cm) of a valve or drain.

**NOTE:** Do not leave cover off for an extended period of time.

Drain the system and drill a hole in the pipe using a hole saw in a slow speed drill (see Fig. 1). Clean the inside pipe of all growth or other material for a distance equal to the pipe diameter on either side of the hole. Roll the vane so that it may be inserted into the hole; do not bend or crease it. Insert the vane so that the arrow on the saddle points in the direction of the waterflow. Take care not to damage the non-corrosive bushing in the saddle. The bushing should fit inside the hole in the pipe. Install the saddle strap and tighten nuts alternately to required torque (see the chart in Fig. 1). The vane must not rub the inside of the pipe or bind in any way.

**CAUTION**

Do not trim the paddle. Failure to follow these instructions may prevent the device from operating and will void the warranty.

**Fig. 1**

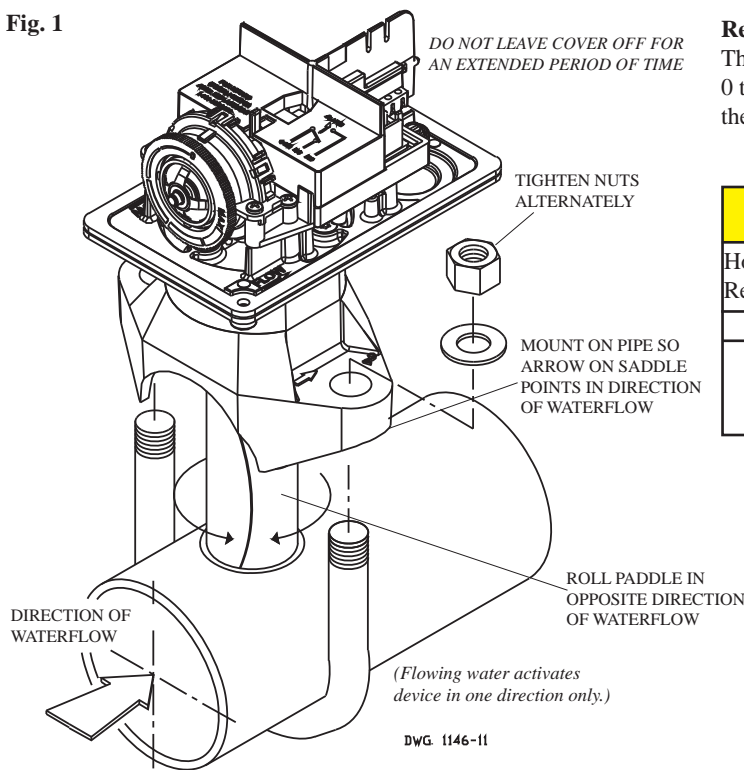

**Retard Adjustment**

The delay can be adjusted by rotating the retard adjustment knob from 0 to the max setting (60-90 seconds). The time delay should be set at the minimum required to prevent false alarms

**CAUTION**

Hole must be drilled perpendicular to the pipe and vertically centered. Refer to the Compatible Pipe/Installation Requirements chart for size.

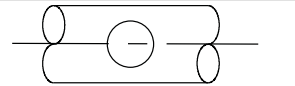
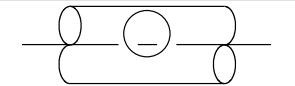
Correct	Incorrect
	

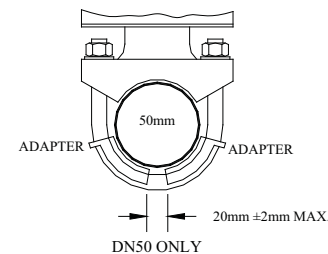

ADAPTER      50mm      ADAPTER

20mm ±2mm MAX.

DN50 ONLY

USE (2) 5180162 ADAPTERS AS SHOWN ABOVE

DWG# 1146-1F

Compatible Pipe/ Installation Requirements																
Model	Nominal Pipe Size		Nominal Pipe O.D.		Pipe Wall Thickness								Hole Size		U-Bolt Nuts Torque	
	inch	mm	inch	mm	Schedule 10 (UL)		Schedule 40 (UL)		BS-1387 (LPC)		DN (VDS)		inch	mm	ft-lb	n-m
VSR-2	2	DN50	2.375	60.3	0.109	2.77	0.154	3.91	0.142	3.6	0.091	2.3	1.25 + .125/-0.062	33.0 ± 2.0	20	27
VSR-2 1/2	2.5	-	2.875	73.0	0.120	3.05	0.203	5.16	-	-	-	-				
VSR-2 1/2	-	DN65	3.000	76.1	-	-	-	-	0.142	3.6	0.102	2.6				
VSR-3	3	DN80	3.500	88.9	0.120	3.05	0.216	5.49	0.157	4.0	0.114	2.9	2.00 ± .125	50.8 ± 2.0		
VSR-3 1/2	3.5	-	4.000	101.6	0.120	3.05	0.226	5.74	-	-	-	-				
VSR-4	4	DN100	4.500	114.3	0.120	3.05	0.237	6.02	0.177	4.5	0.126	3.2				
VSR-5	5	-	5.563	141.3	0.134	3.40	0.258	6.55	-	-	-	-				
VSR-6	6	DN150	6.625	168.3	0.134	3.40	0.280	7.11	0.197	5.0	0.157	4.0				
VSR-8	8	DN200	8.625	219.1	0.148	3.76	0.322	8.18	0.248	6.3	0.177	4.5				

**NOTE:** For copper or plastic pipe use Model VSR-CF.

**Fig. 2**

To remove knockouts: Place screwdriver at inside edge of knockouts, not in the center.

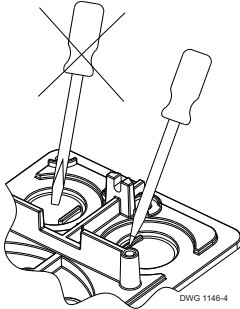

DWG. 1146-4

**NOTICE**

Do not drill into the base as this creates metal shavings which can create electrical hazards and damage the device. Drilling voids the warranty.

**Fig. 3**

Break out thin section of cover when wiring both switches from one conduit entrance.

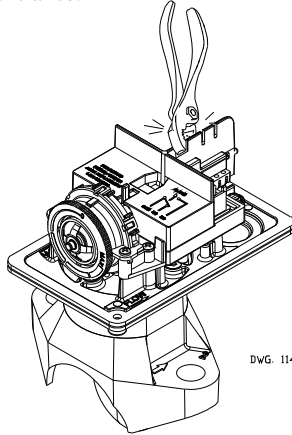

DWG. 1146-13

**Fig. 4**

Switch Terminal Connections Clamping Plate Terminal

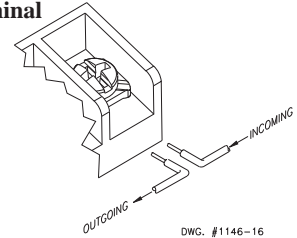

DWG. #1146-16

**WARNING**

An uninsulated section of a single conductor should not be looped around the terminal and serve as two separate connections. The wire must be severed, thereby providing supervision of the connection in the event that the wire become dislodged from under the terminal. Failure to sever the wire may render the device inoperable risking severe property damage and loss of life.

Do not strip wire beyond 3/8" of length or expose an uninsulated conductor beyond the edge of the terminal block. When using stranded wire, capture all strands under the clamping plate.

**Fig. 5 Typical Electrical Connections**

**Notes:**

1. The Model VSR has two switches, one can be used to operate a central station, proprietary or remote signaling unit, while the other contact is used to operate a local audible or visual annunciator.
2. A condition of LPC Approval of this product is that the electrical entry must be sealed to exclude moisture.
3. For supervised circuits, see "Switch Terminal Connections" drawing and warning note (Fig. 4).

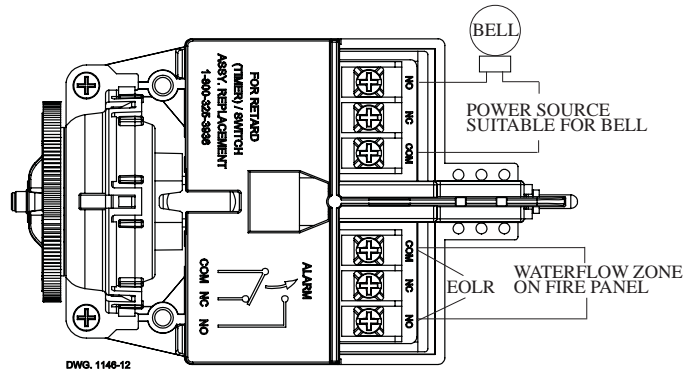

DWG. 1146-12

**Testing**

The frequency of inspection and testing for the Model VSR and its associated protective monitoring system shall be in accordance with applicable NFPA Codes and Standards and/or the authority having jurisdiction (manufacturer recommends quarterly or more frequently).

If provided, the inspector's test valve shall always be used for test purposes. If there are no provisions for testing the operation of the flow detection device on the system, application of the VSR is not recommended or advisable.

A minimum flow of 10 GPM (38 LPM) is required to activate this device.

**NOTICE**

Advise the person responsible for testing of the fire protection system that this system must be tested in accordance with the testing instructions.

**Fig. 7 Mounting Dimensions**

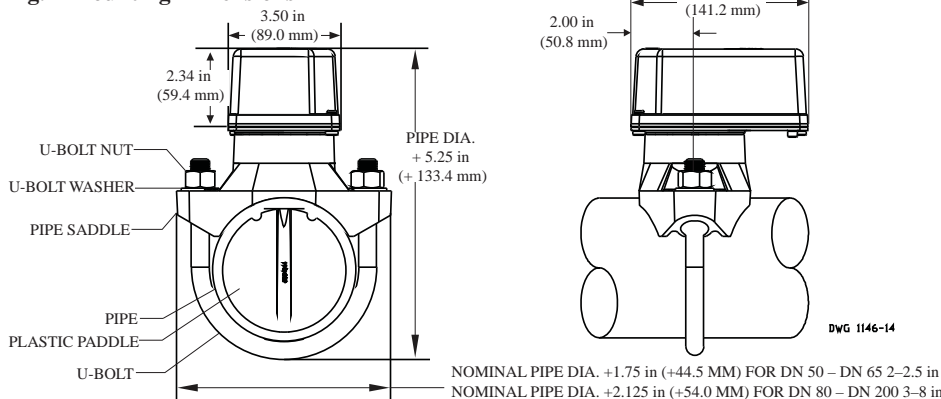

DWG 1146-14

**Fig. 8**

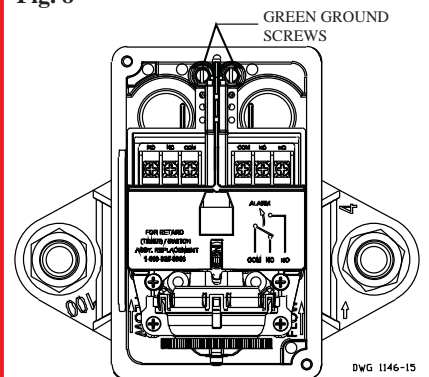

DWG 1146-15

**Maintenance**

Inspect detectors monthly. If leaks are found, replace the detector. The VSR waterflow switch should provide years of trouble-free service. The retard and switch assembly are easily field replaceable. In the unlikely event that either component does not perform properly, please order replacement retard switch assembly stock #1029030 (see Fig. 6). There is no maintenance required, only periodic testing and inspection.

**Retard/Switch Assembly Replacement (See Fig. 6)**

**NOTICE** The Retard/Switch Assembly is field-replaceable without draining the system removing or removing the waterflow switch from the pipe

1. Make sure the fire alarm zone or circuit connected to the waterflow switch is bypassed or otherwise taken out of service.
2. Disconnect the power source for local bell (if applicable).
3. Identify and remove all wires from the waterflow switch.
4. Remove the (2) mounting screws holding retard/switch assembly to the base. **Do not** remove the (2) retard housing screws.
5. Remove the retard assembly by lifting it straight up over the tripstem.
6. Install the new retard assembly. Make sure the locating pins on the retard/switch assembly fit into the locating pin bosses on the base.
7. Re-install the (2) original mounting screws.
8. Reconnect all wires. Perform a flow test and place the system back in service.

**Fig. 6**

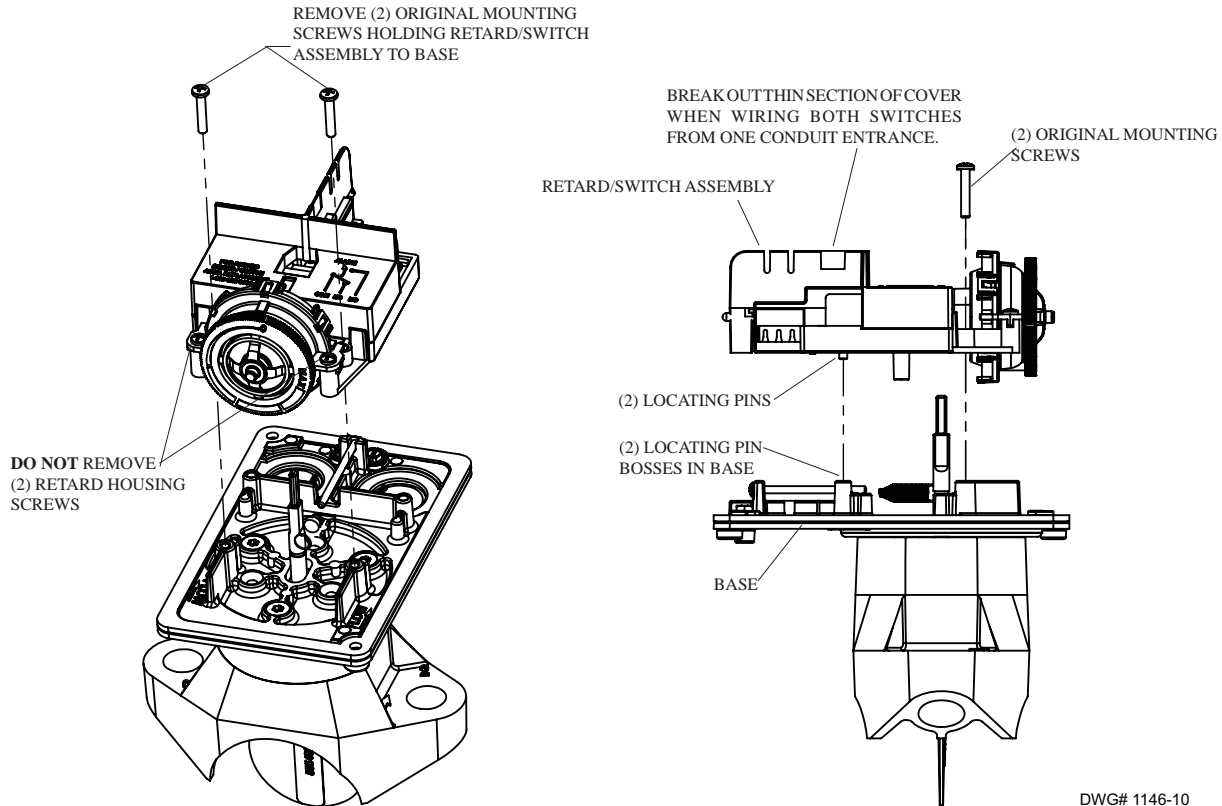

**Removal of Waterflow Switch**

- To prevent accidental water damage, all control valves should be shut tight and the system completely drained before waterflow detectors are removed or replaced.
- Turn off electrical power to the detector, then disconnect wiring.
- Loosen nuts and remove U-bolts.
- Gently lift the saddle far enough to get your fingers under it. With your fingers, roll the vane so it will fit through the hole while continuing to lift the waterflow detector saddle.
- Lift detector clear of pipe.



**Homologué UL, CUL et CSFM, approuvé FM, LPCB Approuvé, marqué pour CE (EN12259-5) / Approuvé VdS modèle VSR-EU**

**Pression d'utilisation :** 450 PSI (31 BAR) - UL

**Échelle de sensibilité au débit pour le Signal :**

4-10 GPM (15-38 LPM) - UL

**Surpression maximale :** 18 pi/s (5,5 m/s)

**Capacité des contacts :** Deux ensembles d'interrupteurs unipolaires bidirectionnels (Form C)

10 A à 125/250 VCA

2 A à 30 VCC résistif

10 mA min. à 24 VCC

**Entrées de conduit :** Deux entrées à alvéoles défonçables par conduit de 1/2 po.

Compartiments à interrupteur séparés et adaptés pour les voltages hétérogènes.

**Critères environnementaux :**

- NEMA 4/AP54 Installation qualifiée adaptée pour l'intérieur ou l'extérieur avec le joint installé en usine et la structure moulée sous pression, si utilisé avec le raccord de conduit approprié.
- Fourchette de température : 40 °F - 120 °F (4,5 °C - 49 °C) - UL
- Gaine de protection non-corrosive installée en usine dans la sellette.

**Utilisation de service :**

Gicleur automatique

NFPA-13

Une ou deux habitations familiales

NFPA-13D

Immeuble d'habitation, jusqu'à quatre étages

NFPA-13R

National Fire Alarm Code

NFPA-72

Renseignements sur les commandes			
Calibre nominal du tuyau		Modèle	Numéro de pièce
2 po	DN50	VSR-2 avec/TSK	1144502
2 1/2 po	DN65	VSR-2 1/2 avec/TSK	1144525
3 po	DN80	VSR-3 avec/TSK	1144503
3 1/2 po	-	VSR-3 1/2 avec/TSK	1144535
4 po	DN100	VSR-4 avec/TSK	1144504
5 po	-	VSR-5 avec/TSK	1144505
6 po	DN150	VSR-6 avec/TSK	1144506
8 po	DN200	VSR-8 avec/TSK	1144508

**Protection du couvercle :** Détecte tout retrait du couvercle

Contact d'interrupteur : Interrupteur unipolaire bidirectionnel (Form C)

Capacité des contacts : 3 A à 250 VCA

5 A à 125 VCA

1 mA à 5 VCC min

Raccordements : 20 cm (8 po) fils conducteurs 22 (calibre américain)

**Éléments remplaçables:** Retard/Switch Assemblée, pas de stock. 1029030

### Renseignements généraux

Le modèle VSR est un interrupteur de débit à ailettes pour utilisation sur des extincteurs automatiques. Il est homologué UL et approuvé FM pour utilisation sur un tuyau en acier; séries 10 à 40, calibres 2 po à 8 po (50 mm à 200 mm). Les calibres approuvés LPC sont de 2 po à 8 po (50 mm à 200 mm). Reportez-vous à la fiche des renseignements sur les commandes.

Le VSR peut aussi être utilisé en tant que détecteur de débit d'eau sectionné pour les gros systèmes.

Le VSR contient deux interrupteurs à pression unipolaires, à deux directions et un décalage pneumatique ajustable à recyclage instantané. Les interrupteurs sont actionnés lorsque le débit est de 10 GPM (38 LPM) en aval de l'appareil. Cette condition d'écoulement doit se produire pendant une période de temps plus longue que la période de décalage sélectionnée.

### AVERTISSEMENT

- L'installation doit être faite par du personnel qualifié et être conforme à tous les règlements et recommandations nationaux ou locaux.
- Risque d'électrocution. Déconnectez la source d'alimentation avant l'entretien. Risque de blessures sérieuses ou de mort
- Risque d'explosion. Non conçu pour une utilisation dans des endroits dangereux. Risque de blessures sérieuses ou de mort.

### ATTENTION

Les interrupteurs de débit qui contrôlent les extincteurs automatiques à eau ne doivent pas être utilisés comme seul dispositif d'amorçage pour le déversement de mousse AFFF, de réseau d'extincteurs, ou de systèmes chimiques d'extinction d'incendie. Les interrupteurs de débit utilisés comme tels peuvent causer des déversements accidentels dus à une surpression, à de l'air emprisonné ou à des temps de décalage courts.

### Enceinte

Les interrupteurs SVR et le dispositif de décalage sont encastrés pour un usage général, dans un corps moulé sous pression. Un interrupteur de protection du couvercle est inclus pour indiquer tout retrait non autorisé du couvercle

**Installation** Reportez-vous à l'illustration 1

Ces dispositifs peuvent être installés sur un tuyau horizontal ou vertical. Sur un tuyau horizontal, ils doivent être installés sur le dessus du tuyau, de manière à être accessibles. Le dispositif ne devrait pas être installé à moins de 6 po (15 cm) d'un raccord qui change la direction du débit d'eau ou à moins de 24 po (60 cm) d'un robinet ou d'un drain.

**Note:** Ne pas laisser couvercle pendant une longue période de temps.

Drainez le système et faites un trou dans le tuyau au moyen d'une scie cylindrique à basse vitesse. (reportez-vous à l'illustration 1)

Dégagez le tuyau intérieur de tout dépôt ou de toute autre substance, à une distance équivalente au diamètre du tuyau, de tous les côtés du trou.

Tournez la pale de manière à ce qu'elle puisse être insérée dans le trou; ne la pliez pas et ne la froissez pas. Insérez la pale de manière à ce que la flèche sur la sellette pointe dans la même direction que le débit d'eau. Attention de ne pas endommager la douille non-corrosive dans la selle.

La douille devrait s'ajuster à l'intérieur du trou dans le tuyau. Installez la sangle de la sellette et serrez les écrous tour à tour, jusqu'au couple de serrage adéquat. (reportez-vous à l'illustration 1) La pale ne doit pas frotter sur l'intérieur du tuyau ou y être attachée de quelque façon que ce soit.

Spécifications sujettes à changement sans préavis.

**ATTENTION**

Ne pas tailler la palette. Ne pas suivre ces instructions pourrait empêcher le dispositif de fonctionner et annuler la garantie.

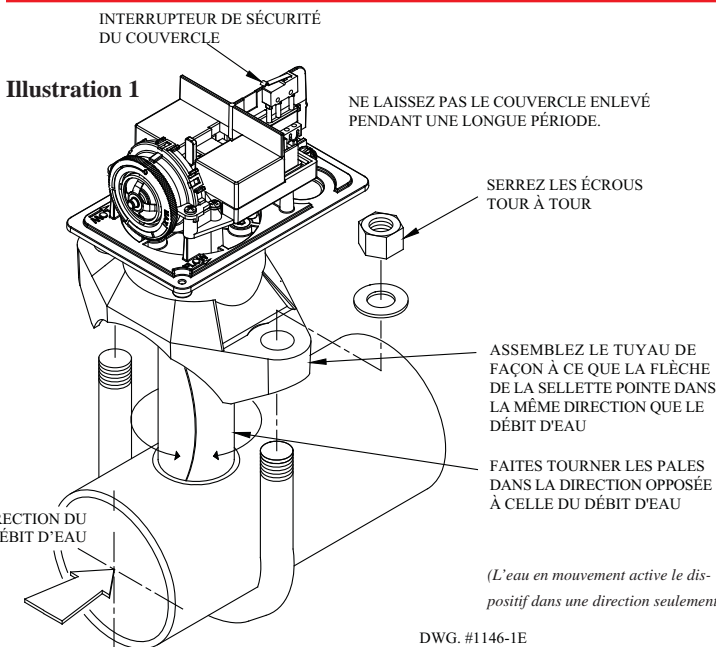

**Adjustement Du Decalage**

Le délai peut être réglé en tournant la poignée d'ajustement du décalage de 0 au réglage maximal (60-90 secondes). Le temps du délai devrait être réglé au minimum, pour prévenir les fausses alarmes.

**ATTENTION**

Le trou doit être foré dans le centre de la pipe. Se référer à Directives d'installation.

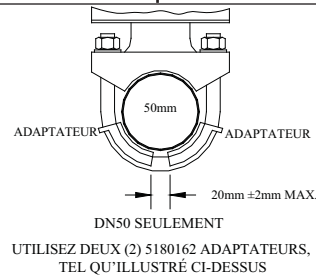

**Tuyau compatible**

Modèle	Calibre nominal du tuyau		Diamètre extérieur nominal du tuyau		Épaisseur de la paroi du tuyau								Taille du trou		Écrou des boulons de serrage en forme de U	
	pouce	mm	pouce	mm	Barème 10 (UL)		Barème 40 (UL)		BS-1387 (LPC)		DN (VDS)		pouce	mm	pied-livre	n-m
					pouce	mm	pouce	mm	pouce	mm	pouce	mm				
VSR-2 avec/TSK	2	DN50	2,375	60,3	0,109	2,77	0,154	3,91	0,142	3,6	0,091	2,3	1,25 + 0,125/- 0,062	33,0 ± 2,0	20	27
VSR-2 1/2 avec/TSK	2 1/2		2,875	73,0	0,120	3,05	0,203	5,16								
VSR-2 1/2 avec/TSK		DN65	3,000	76,1					0,142	3,6	0,102	2,6				
VSR-3 avec/TSK	3	DN80	3,500	88,9	0,120	3,05	0,216	5,49	0,157	4,0	0,114	2,9	2,00 ± 0,125	50,8 ± 2,0		
VSR-3 1/2 avec/TSK	3 1/2		4,000	101,6	0,120	3,05	0,226	5,74								
VSR-4 avec/TSK	4	DN100	4,500	114,3	0,120	3,05	0,237	6,02	0,177	4,5	0,126	3,2				
VSR-5 avec/TSK	5		5,563	141,3	0,134	3,40	0,258	6,55								
VSR-6 avec/TSK	6	DN150	6,625	168,3	0,134	3,40	0,280	7,11	0,197	5,0	0,157	4,0				
VSR-8 avec/TSK	8	DN200	8,625	219,1	0,148	3,76	0,322	8,18	0,248	6,3	0,177	4,5				

**Remarque :** Pour un tuyau de cuivre ou de plastique, utilisez le modèle VSR-CF.

**III. 2**

Pour retirer les entrées à alvéoles défonçables : Placez un tournevis à l'intérieur des entrées défonçables, mais pas au centre.

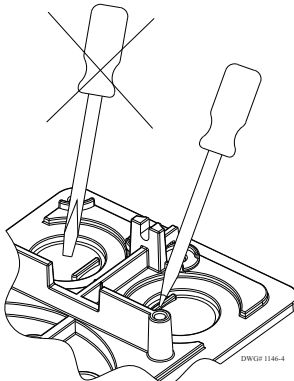

**AVIS**

Ne pas percer dans la base car cela crée des copeaux de métal qui pourraient endommager l'appareil.

**III. 3**

Retirez le couvre-interrupteur dégagez une petite section du couvert lorsque vous connectez les deux interrupteurs d'une entrée de conduit.

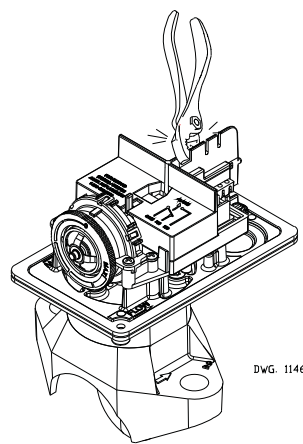

**III. 4**

Connexions de la borne d'interrupteur  
Borne de la plaquette de raccordement

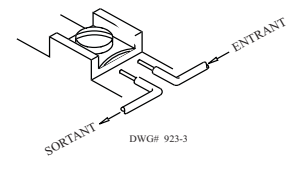

**AVERTISSEMENT**

Une partie non isolée d'un conducteur simple ne devrait pas être enroulée autour de la borne ni être utilisée comme deux connexions séparées. Le fil doit être sectionné, permettant ainsi de contrôler la connexion si le fil se déplace sous le terminal. Le non-respect de cette directive peut rendre le dispositif inefficace, ce qui pourrait causer des dommages matériels et la mort.

**III. 5 Connexions électriques typiques**

**Remarques :**

1. Le modèle VSR comporte deux interrupteurs, dont l'un peut être utilisé pour faire fonctionner une station centrale, comme signaleur à distance ou spécial, alors que l'autre est utilisé pour faire fonctionner un avertisseur visuel ou sonore local.
2. Une des conditions de l'approbation LPC de ce produit est que l'entrée du câble électrique doit être scellée de manière à éviter l'humidité.
3. Pour des directives sur les circuits, reportez-vous au dessin et à l'avertissement de la section « Connexions de la borne d'interrupteur » (illustration 2).

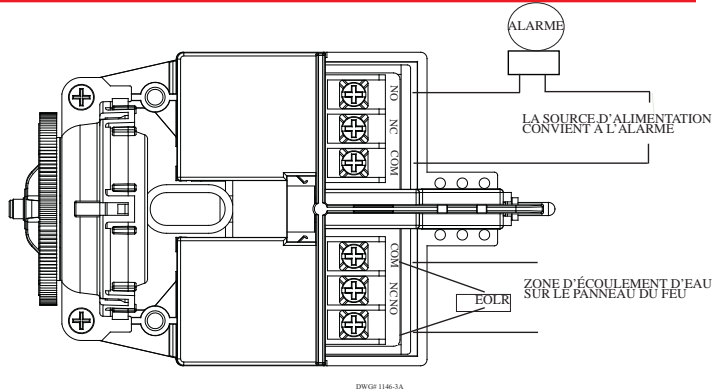

**Essai**

La fréquence d'inspection et d'essai du modèle VSR et des ses systèmes de contrôle associés devrait être conforme aux règlements et aux normes applicables de la NFPA et/ou aux lois en vigueur (le fabricant recommande de le faire à tous les trois mois, ou plus souvent). Utilisez le robinet d'essai, habituellement situé à l'extrémité de l'antenne, uniquement à des fins d'essai du système (si fourni). S'il n'y a pas de dispositions pour tester le fonctionnement du détecteur d'écoulement sur le système, l'installation du VSR n'est ni recommandée ni utile. Un débit minimal de 10 GPM (38 LPM) est requis pour activer ce dispositif.

**AVIS**

Conseillez la personne chargée de l'essai du système de protection contre les incendies que ce système doit être examiné selon les instructions d'essai.

**III. 7 Dimensions de montage**

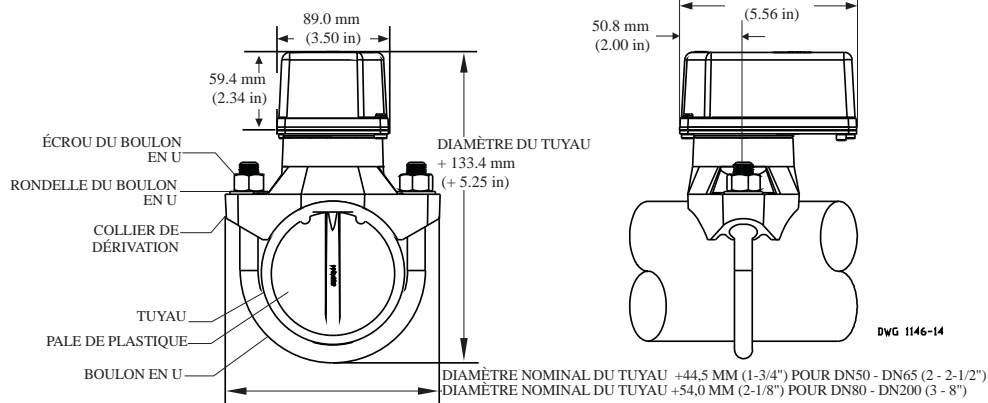

**III. 8**

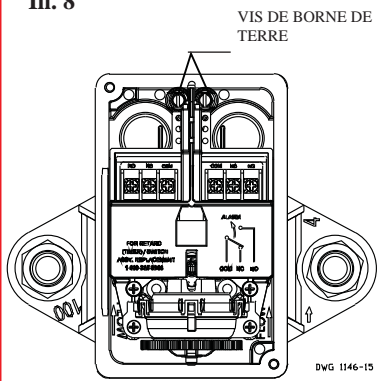

**Entretien**

Vérifiez les détecteurs à tous les mois pour vous assurer qu'il n'y ait pas de fuites. Si vous trouvez une fuite, remplacez le détecteur. L'interrupteur de débit VSR devrait durer des années sans problèmes. L'assemblage de retard et de commutateur est facilement remplaçable sur place. Dans l'événement peu probable que l'un ou l'autre composant n'exécute pas correctement, commander svp les actions #1029030 de commutateur de retard de rechange. Il n'y a aucun entretien exigé, seulement essai et inspection périodiques.

**Remplacement de l'assemblage retardateur/commutateur**

**AVIS** L'assemblage de retardateur/commutateur se remplace sur le terrain sans retirer le régulateur de circulation du tuyau.

1. S'assurer que la zone d'alarme d'incendie ou que le circuit branché au régulateur de circulation est contourné(e) ou retiré(e) du service de quelque autre façon.
2. Couper le courant de l'alarme locale (s'il y a lieu).
3. Identifier et retirer tous les fils du régulateur de circulation.
4. Retirer les deux vis de montage du retardateur.
5. Soulever l'assemblage du retardateur vers le haut sur la tige de déclenchement.
6. Installer le nouvel assemblage du retardateur. S'assurer que les goupilles de guidage du retardateur s'ajustent dans les trous de guidage sur le régulateur de circulation.
7. Fixer le retardateur à la base avec les deux vis déjà retirées.
8. Rebrancher tous les fils. Exécuter un test de débit et remettre le système en service.

**III. 6**

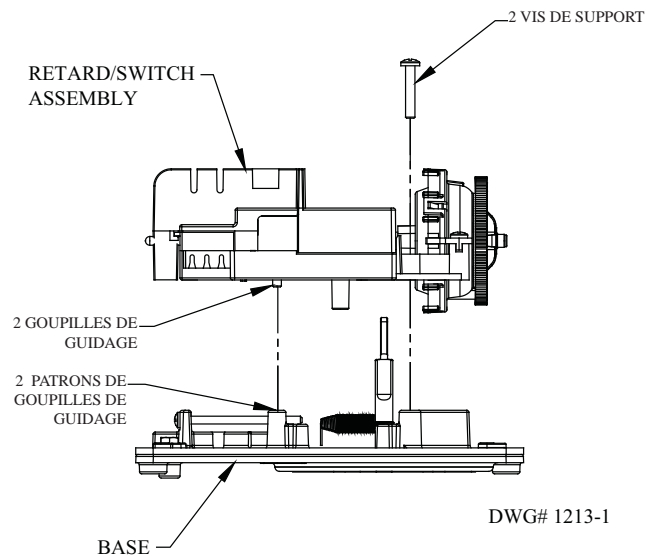
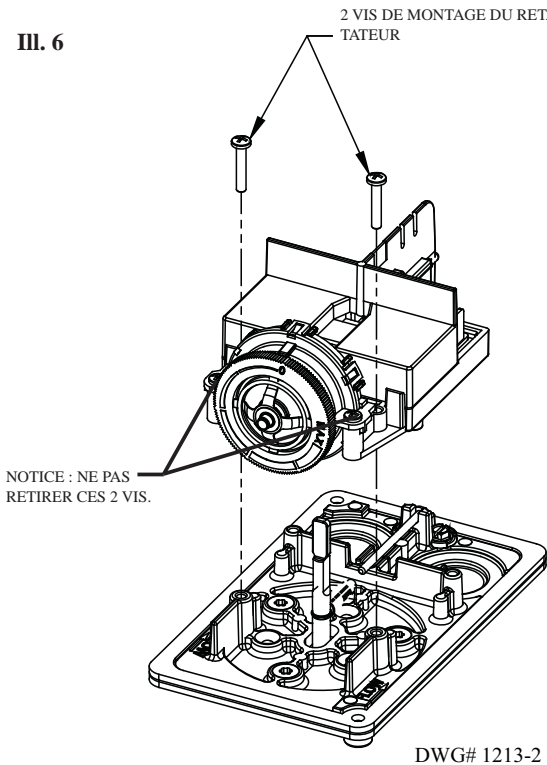

**Retrait**

- Pour prévenir les dégâts d'eau, tous les robinets de contrôle devraient être serrés et le système devrait être drainé en entier avant le retrait ou le remplacement des détecteurs de débit.
- Lorsque vous déconnectez le câblage, fermez toute alimentation électrique du détecteur
- Desserrez les écrous et retirez les boulons en forme de U
- Soulevez doucement la sellette, juste assez pour pouvoir glisser vos doigts en dessous. Avec vos doigts, tournez l'ailette de manière à ce qu'elle entre dans le trou, tout en continuant de lever la sellette du détecteur de débit
- Retirez le détecteur sur le tuyau en levant

# FireLock® V27, K5.6

## Models V2703, V2707, V2704, V2708

### Standard Spray Upright, Pendent and Recessed Pendent Standard and Quick Response



V2703/V2704  
Upright



V2707/V2708  
Pendent



V2707/V2708  
Recessed Pendent

### Approvals/Listings:



See Victaulic Publication [10.01](#) for more details.

### Product Description:

These Model V27 standard spray sprinklers are designed to produce a hemispherical spray pattern for standard commercial applications. They are available with either standard or quick response bulbs. It is cast with a hex-shaped wrench boss to allow easy tightening from many angles, reducing assembly effort. This sprinkler is available in various temperature ratings (see chart on page 3) and finishes to meet many design requirements. The recessed pendent should be utilized with a Model V27 recessed escutcheon which provides up to  $3/4$ "/19 mm of adjustments.

### Coverage

For coverage area and sprinkler placement, refer to NFPA 13 or applicable standard.

### Technical Specifications:

**Models:** V2703, V2704, V2707, V2708

**Style:** Pendent, Upright or Recessed Pendent

**Nominal Orifice Size:**  $1/2$ "/13 mm

**K Factor:** 5.6 Imp./8.1 S.I.<sup>1</sup>

**Nominal Thread Size:**  $1/2$ " NPT/15 mm

**Max. Working Pressure:**

- 175 psi/1200 kPa (FM)
- 250 psi/1725 kPa (UL)

**Factory Hydrostatic Test:** 100% @ 500 psi/3450 kPa

**Min. Operating Pressure:**

- 7 psi/48 kPa
- 0.35 bar/5 psi (VdS for upright only)

**Temperature Rating:** See chart

<sup>1</sup> For K-Factor when pressure is measured in Bar, multiply S.I. units by 10.0.

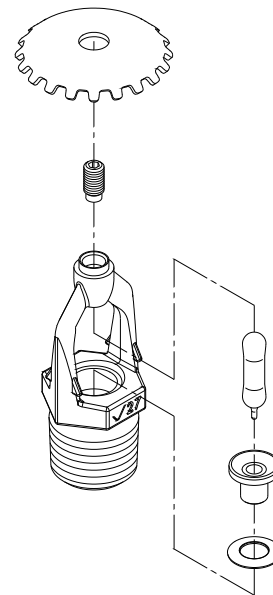

Exaggerated for clarity

### Job/Owner

System No.	
Location	

### Contractor

Submitted By	
Date	

### Engineer

Spec Section	
Paragraph	
Approved	
Date	

**Material Specifications:**

- Upright Deflector:** Bronze per UNS C11000
- Pendent Deflector:** Bronze per UNS C51000
- Bulb:** Glass with glycerin solution
- Bulb Nominal Diameter:**
  - Standard: 5.0 mm
  - Quick Response: 3.0 mm
- Load Screw:** Bronze per UNS C65100
- Pip Cap:** Bronze per UNS C65100
- Spring:** Beryllium nickel
- Seal:** Teflon<sup>2</sup> tape
- Frame:** Die cast brass 65-30
- Lodgement Spring:** Stainless steel per UNS S30200

**Accessories**

---

**Installation Wrench:**

- Open End: V27
- Recessed: V27-2

**Sprinkler Finishes:**

- Plain Brass
- Chrome plated
- White painted<sup>3</sup>
- Black painted<sup>3</sup>
- Custom painted<sup>3</sup>
- Proprietary Nickel Teflon<sup>2</sup> coating<sup>3</sup>
- VC-250<sup>4</sup>

**155, 200, 286 SR Only:**

- Wax<sup>3</sup>

For cabinets and other accessories refer to separate sheet.

<sup>2</sup> Teflon is a registered trademark of Dupont Co.

<sup>3</sup> UL Listed for corrosion resistance.

<sup>4</sup> UL Listed and FM Approved for corrosion resistance.

**Approvals/Listings:**

APPROVALS/LISTINGS	Model					
	V2703	V2707	V2707	V2704	V2708	V2708 <sup>7</sup>
Orifice Size (inches)	1/2"	1/2"	1/2"	1/2"	1/2"	1/2"
Orifice Size (mm)	13	13	13	13	13	13
Nominal K Factor Imperial	5.6	5.6	5.6	5.6	5.6	5.6
Nominal K Factor S.I. <sup>5</sup>	8.1	8.1	8.1	8.1	8.1	8.1
Response	Standard	Standard	Standard	Quick	Quick	Quick
Deflector Type	Upright	Pendent	Recessed Pendent	Upright	Pendent	Recessed Pendent
<b>Approved Temperature Ratings</b>	<b>F°/C°</b>					
cULus	135°F/57°C 155°F/68°C 175°F/79°C 200°F/93°C 286°F/141°C 360°F/182°C	135°F/57°C 155°F/68°C 175°F/79°C 200°F/93°C 286°F/141°C 360°F/182°C	135°F/57°C 155°F/68°C 175°F/79°C 200°F/93°C 286°F/141°C	135°F/57°C 155°F/68°C 175°F/79°C 200°F/93°C 286°F/141°C	135°F/57°C 155°F/68°C 175°F/79°C 200°F/93°C 286°F/141°C	135°F/57°C 155°F/68°C 175°F/79°C 200°F/93°C
FM	135°F/57°C 155°F/68°C 175°F/79°C 200°F/93°C 286°F/141°C 360°F/182°C	135°F/57°C 155°F/68°C 175°F/79°C 200°F/93°C 286°F/141°C 360°F/182°C	135°F/57°C 155°F/68°C 175°F/79°C 200°F/93°C	135°F/57°C 155°F/68°C 175°F/79°C 200°F/93°C 286°F/141°C	135°F/57°C 155°F/68°C 175°F/79°C 200°F/93°C 286°F/141°C	135°F/57°C 155°F/68°C 175°F/79°C 200°F/93°C
NYC/MEA 62-99-E	135°F/57°C 155°F/68°C 175°F/79°C 200°F/93°C 286°F/141°C 360°F/182°C	135°F/57°C 155°F/68°C 175°F/79°C 200°F/93°C 286°F/141°C 360°F/182°C	135°F/57°C 155°F/68°C 175°F/79°C 200°F/93°C 286°F/141°C	135°F/57°C 155°F/68°C 175°F/79°C 200°F/93°C 286°F/141°C	135°F/57°C 155°F/68°C 175°F/79°C 200°F/93°C 286°F/141°C	135°F/57°C 155°F/68°C 175°F/79°C 200°F/93°C
CSFM 7690-0531:112	135°F/57°C 155°F/68°C 175°F/79°C 200°F/93°C 286°F/141°C 360°F/182°C	135°F/57°C 155°F/68°C 175°F/79°C 200°F/93°C 286°F/141°C 360°F/182°C	135°F/57°C 155°F/68°C 175°F/79°C 200°F/93°C 286°F/141°C	135°F/57°C 155°F/68°C 175°F/79°C 200°F/93°C 286°F/141°C	135°F/57°C 155°F/68°C 175°F/79°C 200°F/93°C 286°F/141°C	135°F/57°C 155°F/68°C 175°F/79°C 200°F/93°C
LPCB	135°F/57°C 155°F/68°C 175°F/79°C 200°F/93°C 286°F/141°C 360°F/182°C	None	None	135°F/57°C 155°F/68°C 175°F/79°C 200°F/93°C	None	None
VNIPO	135°F/57°C 155°F/68°C 175°F/79°C 200°F/93°C 286°F/141°C 360°F/182°C	135°F/57°C 155°F/68°C 175°F/79°C 200°F/93°C 286°F/141°C 360°F/182°C	135°F/57°C 155°F/68°C 175°F/79°C 200°F/93°C	135°F/57°C 155°F/68°C 175°F/79°C 200°F/93°C 286°F/141°C	135°F/57°C 155°F/68°C 175°F/79°C 200°F/93°C 286°F/141°C	135°F/57°C 155°F/68°C 175°F/79°C 200°F/93°C
CCC	ZSTZ 155°F/68°C 200°F/93°C	ZSTX 155°F/68°C 200°F/93°C	None	K-ZSTZ 155°F/68°C 200°F/93°C	K-ZSTZ 155°F/68°C 200°F/93°C	None
VdS	135°F/57°C 155°F/68°C 175°F/79°C 200°F/93°C 286°F/141°C 360°F/182°C	None	None	135°F/57°C 155°F/68°C 175°F/79°C 200°F/93°C 286°F/141°C	None	None
CE	135°F/57°C 155°F/68°C 175°F/79°C 200°F/93°C 286°F/141°C 360°F/182°C	None	None	135°F/57°C 155°F/68°C 175°F/79°C 200°F/93°C 286°F/141°C	None	None

<sup>5</sup> For K Factor when pressure is measured in Bar, multiply S.I. units by 10.0

<sup>7</sup> FM Approved with 1/2" adjustment escutcheon only - quick response

Note: Listings and Approvals as of printing. All are approved open.

Dimensions:

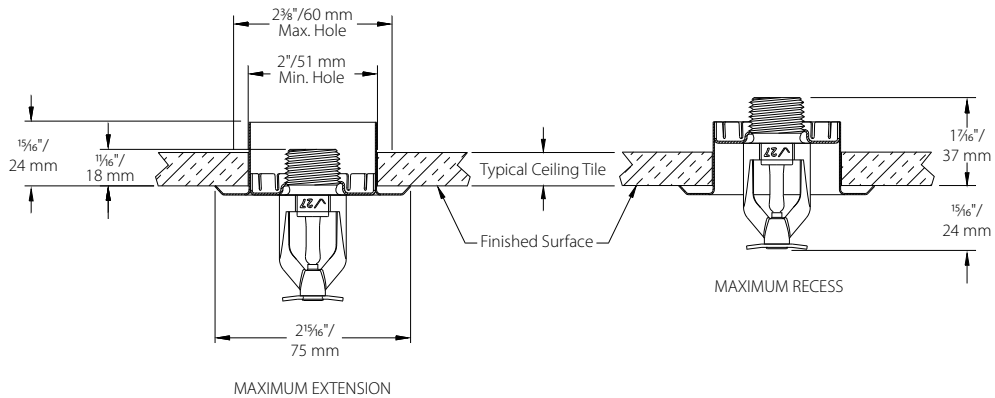
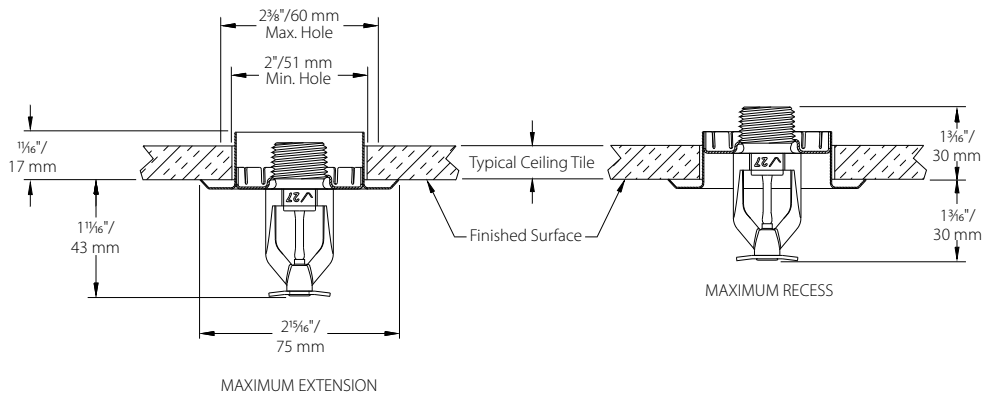
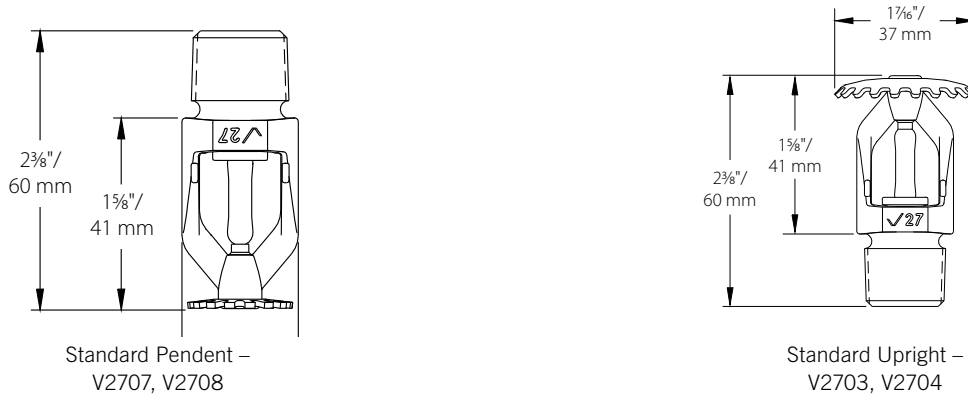

**Distribution Patterns:**

Models V2707, V2708  
K5.6 Standard Pendent and Recessed Pendent  
Distribution Patterns – Trajectory

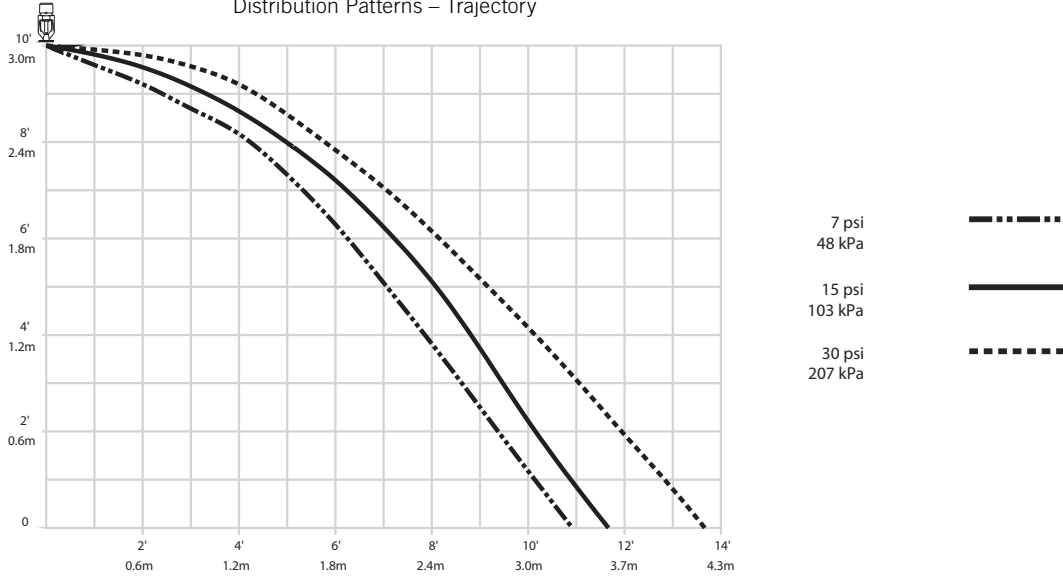

Models V2703, V2704  
K5.6 Standard Upright  
Distribution Patterns – Trajectory

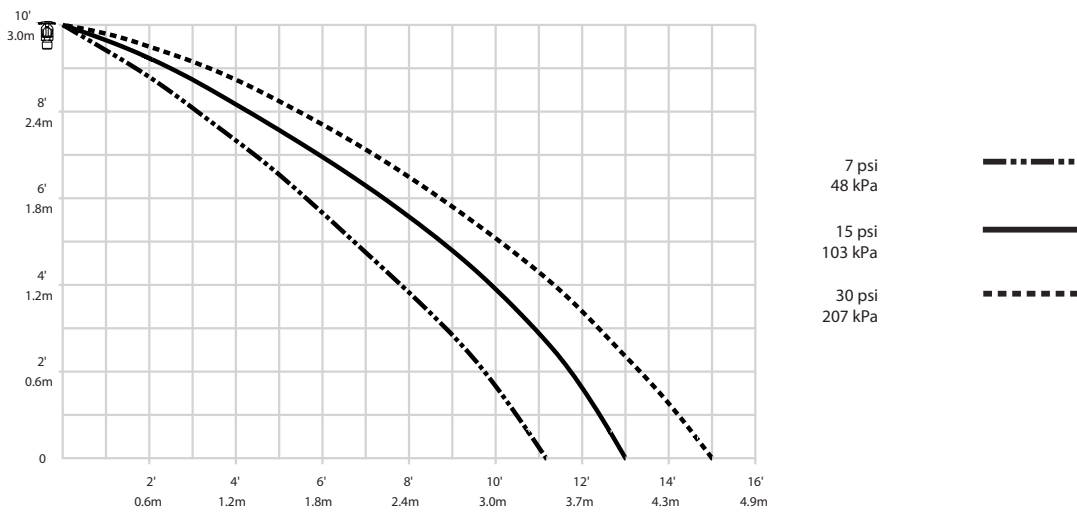

**NOTES:**

- A. Data shown is approximate and can vary due to differences in installation.
- B. These graphs illustrate approximate trajectories, floor-wetting, and wall-wetting patterns for these specific Victaulic FireLock Automatic Sprinklers. They are provided as information for guidance in avoiding obstructions to sprinklers and should not be used as minimum sprinkler spacing rules for installation. **Refer to the appropriate NFPA National Fire Code or the Authority Having Jurisdiction for specific information regarding obstructions, spacing limitations and area of coverage requirements.** Failure to follow these guidelines could adversely affect the performance of the sprinkler and will void all Listings, Approvals and Warranties.
- C. All patterns are symmetrical to the centerline of the waterway.

**Ratings:**

All glass bulbs are rated for temperatures from -67°F (-55°C) to those shown in the table below.

Sprinkler Temperature Classification	Victaulic Part Identification	Temperature – °F/°C		Glass Bulb Color
		Nominal Temperature Rating	Maximum Ambient Temperature Allowed	
Ordinary	A	135°F/57°C	100°F/38°C	Orange
Ordinary	C	155°F/68°C	100°F/38°C	Red
Intermediate	E	175°F/79°C	150°F/65°C	Yellow
Intermediate	F	200°F/93°C	150°F/65°C	Green
High	J	286°F/141°C	225°F <sup>8</sup> /107°C	Blue
Extra High <sup>7</sup>	K	360°F/182°C	300°F/149°C	Purple
–	M	Open	–	No Bulb



<sup>7</sup> Standard response only.

<sup>8</sup> 150/65 if wax coated.

**Available Wrenches:**

	V27-2 Recessed	V27 Open End
V2707, V2708 Pendent	✓	✓
V2707, V2708 Recessed Pendent	✓	–
V2703, V2704 Upright	–	✓

**⚠ WARNING**

- Always read and understand installation, care, and maintenance instructions, supplied with each box of sprinklers, before proceeding with installation of any sprinklers.
- Always wear safety glasses and foot protection.
- Depressurize and drain the piping system before attempting to install, remove, or adjust any Victaulic piping products.
- Installation rules, especially those governing obstruction, must be strictly followed.
- Painting, plating, or any re-coating of sprinklers (other than that supplied by Victaulic) is not allowed.

Failure to follow these instructions could result in serious personal injury and/or property damage.

The owner is responsible for maintaining the fire protection system and devices in proper operating condition. For minimum maintenance and inspection requirements, refer to the current National Fire Protection Association pamphlet that describes care and maintenance of sprinkler systems. In addition, the authority having jurisdiction may have additional maintenance, testing, and inspection requirements that must be followed.

If you need additional copies of this publication, or if you have any questions about the safe installation of this product, contact Victaulic World Headquarters: P.O. Box 31, Easton, Pennsylvania 18044-0031 USA, Telephone: 001-610-559-3300.

**Installation**

Reference should always be made to the I-40 Victaulic FireLock Automatic Sprinklers Installation and Maintenance Sheet for the product you are installing. This installation sheet is included with each shipment of Victaulic products for complete installation and assembly data, and is available in PDF format on our website at victaulic.com.

**Warranty**

Refer to the Warranty section of the current Price List or contact Victaulic for details.

**Note**

This product shall be manufactured by Victaulic or to Victaulic specifications. All products to be installed in accordance with current Victaulic installation/assembly instructions. Victaulic reserves the right to change product specifications, designs and standard equipment without notice and without incurring obligations.

**Trademarks**

Victaulic is a registered trademark of Victaulic Company.